

(Importers and Distributors of Electronic Equipment)

11 Normanby Street, Prahran, Vic. 3181, Australia

PO Box 3167

Telephone: (03) 9529 3660 International: 61 3 9529 3660

Fax: (03) 9529 7524 International: 61 3 9529 7524

E-mail: sales@interscientific.com.au

Web: www.interscientific.com.au

VIBRATION CONDITION MONITORING SYSTEM SCREW IN M8 X 1/4-28 UNF ACCELEROMETER MOUNTING STUD

PART NO.: F/1428M8B
MATERIAL: Grade 401 Stainless Steel

\$25 plus GST

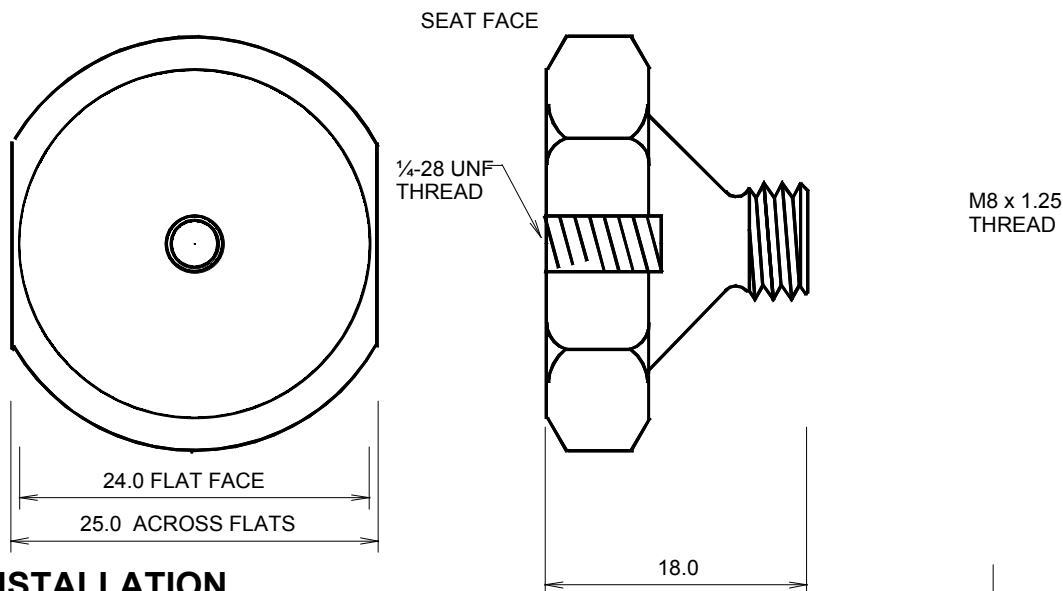

INSTALLATION

1. Drill a 6.8 mm (17/64") diameter hole x 9 mm deep (ie 11.5 mm max hole depth to drill point) at the selected monitoring location. (NB. The stud location should allow sufficient clearance for use of either a 26 or a 42 mm diameter accelerometer.)
2. Machine a chamfered mounting seat using a 90° countersinking tool to provide no more than 1-1.5 mm wide seat face.
3. Tap hole with an M8 x 1.25 mm pitch thread to provide 8 mm of full thread.
NB. Use a plug tap and ensure that the hole and thread are thoroughly cleaned out.
4. Install the stud to seat evenly on the countersink and lightly torque to 10-15 Nm. It is important that the stud does not bottom in the hole or mate with the machine surface except by the seat face. (These conditions can produce excessive / reduced transmitted vibration levels.)
NB. Use a thread locking compound (eg Loctite) on machines having high vibration.